

PLS-700

Univox Loop driver Installation Guide



PLS-700, Part No 214700

Maximum area coverage in free field conditions

- With 4 parallel multi-loops 1800 m²
- With a perimeter loop 1:1-1:3 room ratio 700 m²

Note that metallic interference will impact on the coverage by 30 % to total dampening depending on loop wire placement.

Overview

Univox® PLS-700 Front panel



A1-3. Input check

B. Loop check

C. Loop monitor, 6.3 mm jack and volume adjust

D. Mains power indicator

Univox® PLS-700 Rear panel

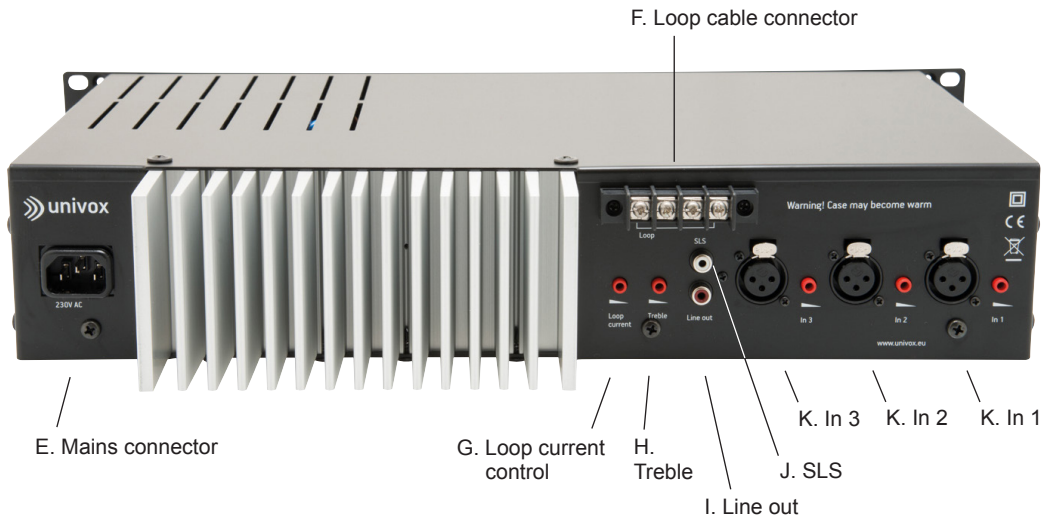

F. Loop cable connector

E. Mains connector

G. Loop current control

H. Treble

I. Line out

J. SLS

K. In 3

K. In 2

K. In 1

Recommended minimum loop area for Univox® PLS-700 when installed to an existing perimeter loop system

Loop area m ²	Wire area 1-turn-loop	Wire area 2-turn-loop
> 300	> = 5 mm ²	Not recommended
150-300	> = 4 mm ²	2 x 2.5 mm ²
70-150	Not recommended	2 x 2.5 mm ²
20-70	Not recommended	2 x 2.5 mm ²



Univox® FSM 2.0
Field Strength Meter
Part No 401040



Univox® Listener
Loop testing device
Part No 401010

Installation

General planning and installation procedures.

1. Preparations

- a) If the loop cable is already planned, install according to the drawings. Then read clause 2.
- b) if the loop cable is already planned and installed, read clause 2.
- c) If the loop cable is to be planned and installed "in situ", please read the following hints.

Hints for planning the loop cable

- Use a 2 x 2.5 mm² twin loop wire, this gives a high flexibility for the installer. If other loop wires are used, the loop driver's efficiency may be affected. Recommended minimum loop wire area is described in the table on page 3.
- If the space for the loop cable is limited, a flat copper foil (Part No 861023 or Part No 861025) can be used as an alternative.
- The field strength can be reduced due to reinforcement ironing and such like. If so, the field strength can be doubled (appr. 6 dB) if 2 loop driver's are used, one for each separate wire of the twin wire, or use a more powerful loop driver as an alternative. Do not place input cables close to / in parallel with the loop wire.
- Do not place the loop wire close to reinforcement iron and such like.
- If the smallest distance in a loop exceeds 10 meters, please consider another loop configuration, like the "eight"-loop.
- Please be aware of the overspill effect. If the overspill is not acceptable, plan the system for Univox® Super Loop System® with minimized overspill. Log on to www.univox.eu for more information.
- Beware of the background noises created by other electrical equipment when planning the loop system.
- Proceed to clause 2.

2. Installation

Mount the loop driver

in a 19"-rack.

Important!

The loop driver must have free access to normal room temperature. In a 19" rack, a minimum clearance of 1U (44 mm) above and below the unit must be left for ventilation.

	Sensitivity	Impedance	Priority	
IN1 / Mic	0.5 mV-100 mV	7.8 kOhm	IN1 > IN3	Default setting
IN1 / Line	25 mV-4 V	-"-		
IN2 / Mic	0.5 mV-100 mV	-"-		
IN2 / Line	25 mV-4 V	-"-		Default setting
IN3 / Mic	0.5 mV-100 mV	-"-		
IN3 / Line	25 mV-4 V	-"-	IN3 < IN1	Default setting

Connect the loop cable

Connect the loop cable to terminal **F** on the rear panel. Please look at page 4 for 1- or 2-turn loop connections.

Connect signal source/s

to the inputs "IN1-3", **K**, **L** och **M** on the rear panel. See page 4 for balanced/unbalanced connections. The inputs "IN1-3" can be set to different sensitivities according to table. If you need to set IN1-3 otherwise than default, remove the cover and set the switches S1-20 according to table at page 4.

Important! Disconnect the mains power before removing the cover.

Input-AGC

The AGC-function for inputs IN1-3 can be disabled by setting the switch S18 according to table on page 4.

Connect Line Outputs

Univox PLS-700 has 2 line outputs; **I** = "LINE OUT" 0dBm without the input AGC activated (linear), and **J** "SLS" 0 dBm with the AGC-function activated.

Connect mains power

to the inlet **E**. The LED **D** on the front panel starts lighting. Univox PLS-700 has an automatic resettable built-in mains fuse. If it's triggered by any reason, please remove the mains power and let the loop driver cool off. Investigate the possible fault reason before reconnecting the mains power.

3. Function check (basic start up check)

Adjust the input levels

one by one letting the LED **A1-3** on the front panel emitting at the peaks of the program signal source (AGC knee).

Increase

the Loop Current trimmer **G** until the first LED **B** on the front panel lits up. Use the loop monitor output **C** for direct listening to the output current (magnetic field). If necessary, adjust TREBLE with the potentiometer **H**.

4. Certification – Important!

Adjust the loop driver

following "The Univox Way" for certification according to IEC-60118-4 using a field strength meter, like the Univox FSM 2.0. Univox FSM follows the standard of Sound Meter with correct integration time and true RMS measurement.

5. Inform people responsible for the Loop System

how to use the system. Recommend a listening device for a daily basic check of the loop system. Univox Listener is a high quality listening device with built-in level check.

Connections

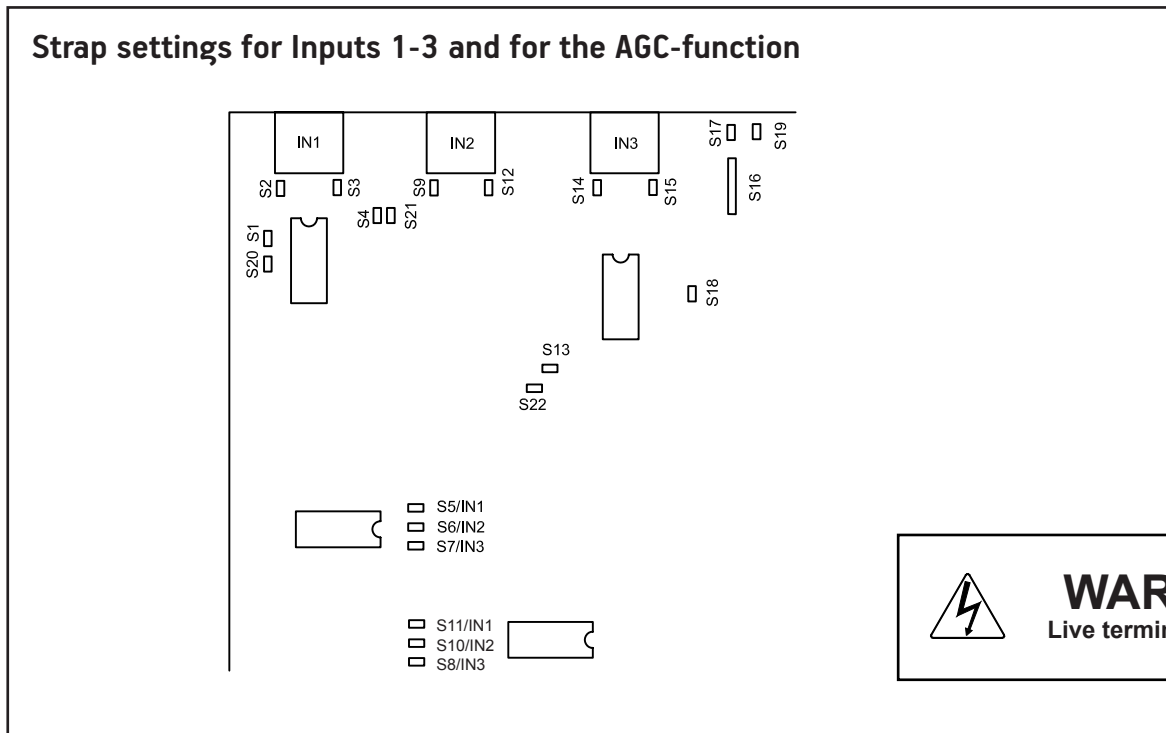
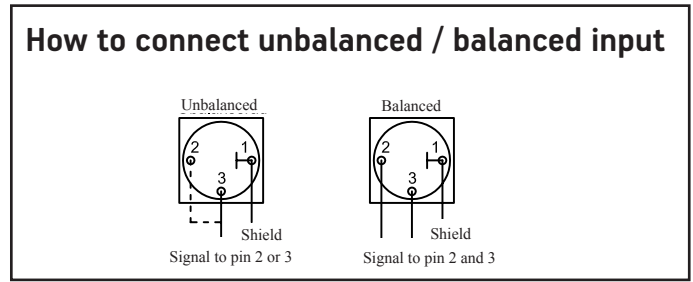
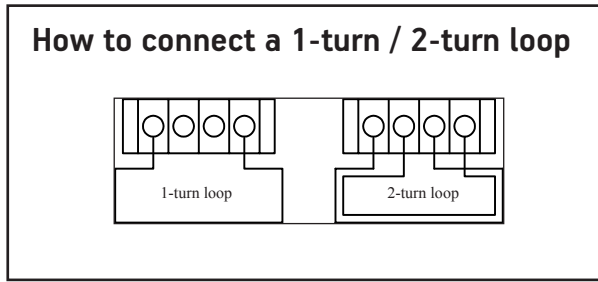

Disconnect the mains power before removing the cover!

IN1

Phantom power on (Default): S2 & S3 closed. Phantom power off: S2 & S3 open.

Microphone sensitivity (Default): S1 & S20 open. Line sensitivity: S1 & S20 closed.

IN2

Phantom power on: S9 & S12 closed. Phantom power off (Default): S9 & S12 open.

Microphone sensitivity: S4 & S21 open. Line sensitivity (Default): S4 & S21 closed.

IN3

Phantom power on: S14 & S15 closed. Phantom power off (Default): S14 & S15 open.

Microphone sensitivity: S13 & S22 open. Line sensitivity (Default): S13 & S22 closed.

AGC

AGC on (Default): S18 closed. AGC off: S18 open.

Priority

Closing of the following jumpers is used to determine which inputs are going to muffle the other inputs: S11 (IN1, Default), S10 (IN2) & S8 (IN3).

Closing of the following jumpers is used to determine which inputs can be muffled by other inputs: S5 (IN1), S6 (IN2) & S7 (IN3, Default).

If jumper S5 (IN1), S6 (IN2) or S7 (IN3) is left open the input cannot be muffled regardless of the setting of S11, S10 & S8.

Attention!

Jumpers S16, S17 & S19 shall NOT be changed!

Warranty

Basic knowledge in audio and video installation techniques is required to achieve existing regulations. The installer/planner is responsible for the installation hereby avoiding any risk or cause of fire.

Please note that the warranty is not valid for any damage or defects on the product due to incorrect or incautious installation (or usage) or maintenance. Bo Edin AB is not responsible for interference from radio or TV equipment, or damage caused by the product to any property or liable for the consequences of such damages.

Maintenance and care

Under normal circumstances Univox® loop amplifiers (the product) do not need any special maintenance. Should the unit become dirty, wipe it with a clean damp cloth. Do not use solvent or strong detergents.

Trouble shooting

Verify the control LEDs following the instructions in this installation guide. Use Univox® Listener to check the sound quality and basic level of the loop.

Service

Should the product/system not work after having made the product test as described above, please contact the local distributor of the product for further instructions. If the product should be sent to Bo Edin AB, please enclose a filled Service Form, www.univox.eu/Support.

Technical data

For additional information, please refer to product data sheet/brochure and CE certificate which can be downloaded from www.univox.eu/Downloads. If required other technical documents can be ordered from support@edin.se.

Environment/Correct Disposal

When this product is finished with, please follow existing disposal regulations. Thus if you respect these instructions you ensure human health and environmental protection.



Distributor

Univox by edin, the world's leading expert and producer of high quality hearing loop systems, created the very first true loop amplifier 1969. Ever since our mission is to serve the hearing community with the highest degree of service and performance with strong focus on Research and Development for new technical solutions.

Bo Edin AB Stockby Hantverksby 3, SE-18175 Lidingö, Sweden
Visit Förrådsvägen 2 B, SE-18141 Lidingö, Sweden

Phone +46 8 767 18 18
Fax +46 8 767 18 20

E-mail info@edin.se
Internet edin.se • univox.eu